

# Recirculation Kit

*Iso Pump Lubrication System*

For pump lubrication on Guardian proportioners.

	<p><b>Important Safety Instructions</b> Read all warnings and instructions in this manual and your proportioner manual. Save both sets of instructions.</p>
---	---

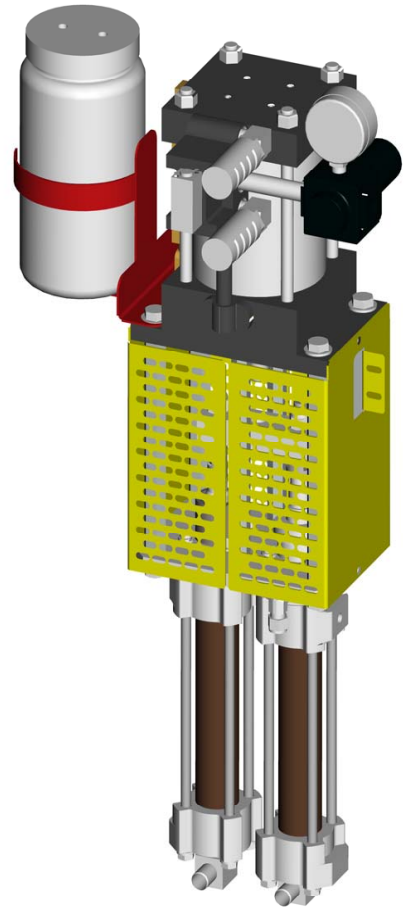

# Table Of Contents

**Section 1 Installation**

1:1 Introduction ..... 1  
1:2 Standard Equipment ..... 2  
1:3 Installation ..... 3

**Section 2 General Information**

2:1 Assembly Drawing ..... 7

**Section 3 Warranty and Reference Information**

3:1 Limited Warranty Policy ..... 9  
3:2 Technical Assistance ..... 10  
**For Your Reference** ..... INSIDE BACK COVER

# Section 1 - Installation

## Introduction

Before operating, maintaining or servicing any **GlasCraft** system, read and understand all of the technical and safety literature provided with **GlasCraft** products. If you do not have the proper or related manuals and safety literature for your **GlasCraft** system, contact your **GlasCraft** distributor.

In this **GlasCraft** technical and safety publication, the following advisories will be provided where appropriate:



Is information about the procedure in progress.



*Is imperative information about equipment protection.*



*Indicates a hazardous situation which, if not avoided, could result in minor or moderate injury.*



*Indicates a hazardous situation which, if not avoided, could result in death or serious injury.*



*Indicates a hazardous situation which, if not avoided, could result in electrical shock or serious injury.*

The information in this document is intended only to indicate the components and their normal working relationship typical use. Each assembly should be directed by a **GlasCraft** distributor or made from the **GlasCraft** Assembly instructions provided.

This manual provides information for the assembly, operation, maintenance and service of this **GlasCraft** product as used in a typical configuration. While it lists standard specifications and procedures, some deviations may be found.

In order to provide our users with the most up-to-date technology possible, we are constantly seeking to improve products. If technological change occurs after a product is on the market, we will implement that technology in future production and, if practical, make it available to current users as a retrofit, up-date or supplement. If you find some discrepancy between your unit and the available documentation, contact your **GlasCraft** distributor to resolve the difference.

Careful study and continued use of this manual will provide a better understanding of the equipment and process, resulting in more efficient operation, longer trouble-free service and faster, easier troubleshooting.

## Section 1 - Installation

Sec. 1:2

### Recirculation Kit

Standard Equipment	
Part	Description
GC1845	RECIRCULATION KIT
313285	USER MANUAL

## Section 1 - Installation

1. Dump pressure off system

**WARNING**

Be sure air and power are off to system.

This is achieved by removing side blocks from the gun, opening ball valves and purging materials into clean containers.

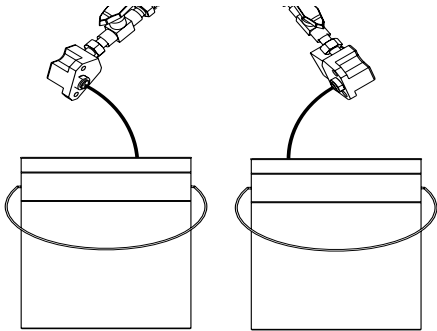

2. Flush system with suitable solvent.

3. Disconnect inlet and outlet fittings from the ISO pump.

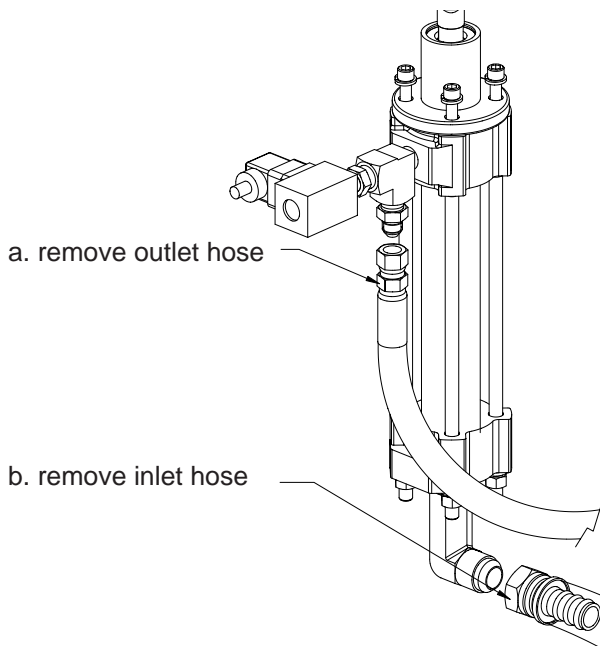

4. Disconnect the din connector from over pressure switch.

- a. remove plug

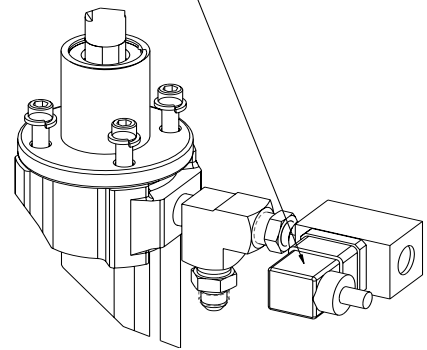

- b. Remove Switch from fitting.

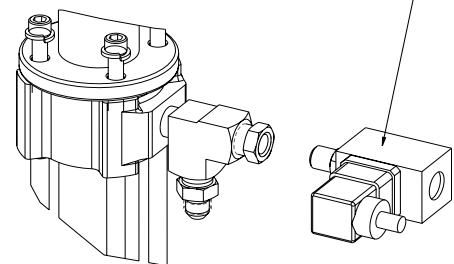

Do not immerse Over Pressure Valve in solvents externally. (Flushing will not affect).

5. Remove the ISO pump from the proportioning unit.

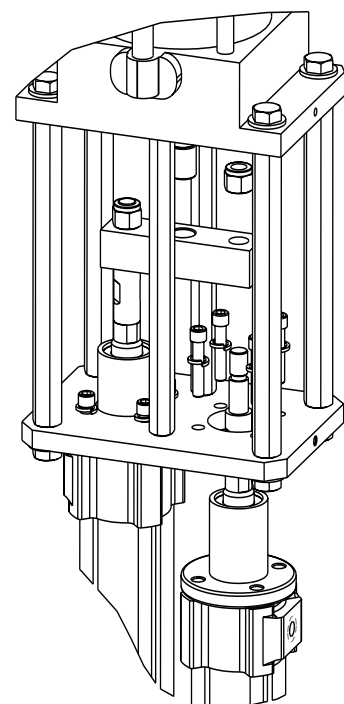

## Section 1 - Installation

6. Remove the ISO pump shaft extension.

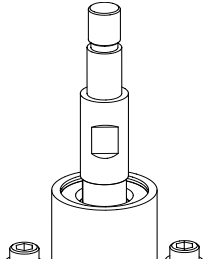

7. Remove the retaining ring and felt wipers from the ISO pump.

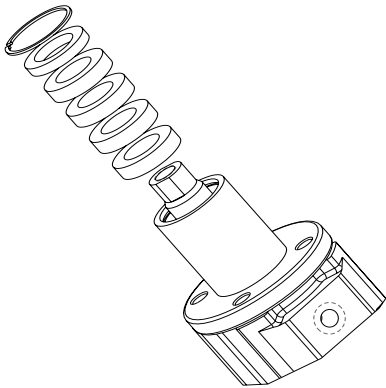

9. Disassemble the sub-assembly.

a. Remove the support washer.

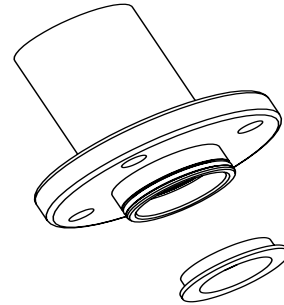

b. Remove the seal. Save or discard the solvent cup and o-ring.

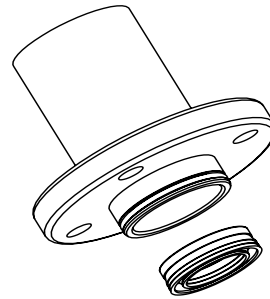

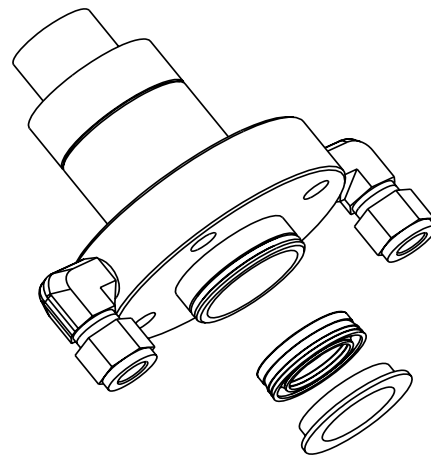

10. Install the seal and support washer to the new solvent cup adapter assembly included with the kit.

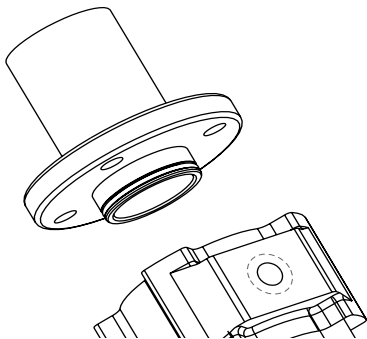

 *The parts removed in steps 6 & 7 will NOT be used in the new assembly. They can be saved or discarded.*

8. Remove the housing from the pump head.



 *Lightly lubricate the o-ring and seal with a light weight non-detergent oil or grease.*

## Section 1 - Installation

**11.** Install the new sub assembly to the pump head.

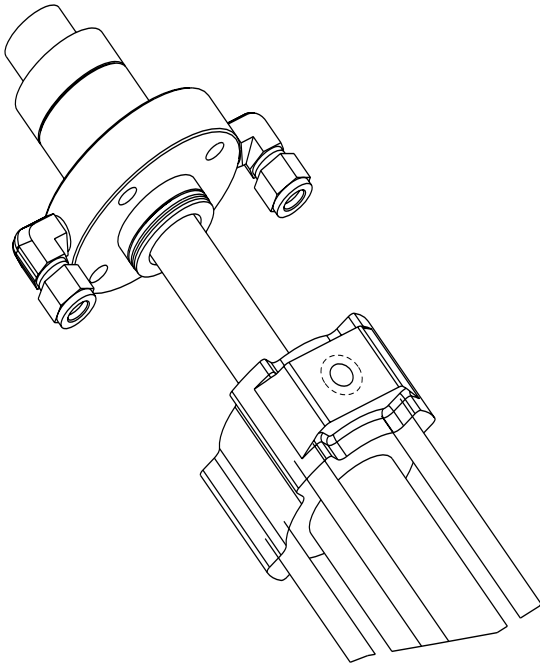

**13.** Reattach the ISO pump to the pump plate. Attach the pump shaft extension to the pump saddle *ONE* and *TWO*. Tighten the pump to the plate using the new mounting bolts and lock washers provided with the kit (this will allow for proper alignment).



*To ensure proper alignment:*

- a.** With shaft nut (1) and mounting bolt (2) loosely threaded, slightly rotate pump back and forth within pump plate until it is centered.
- b.** Tighten shaft nut (1). (Must perform this step before tightening mounting bolts.)
- c.** Tighten four mounting bolts (2).



*Lightly lubricate the o-rings with a light weight non-detergent oil or grease.*

**12.** Assemble the shaft extension GC1839 (included with the kit) to the ISO pump shaft. Use *blue Loctite®* on the threads.

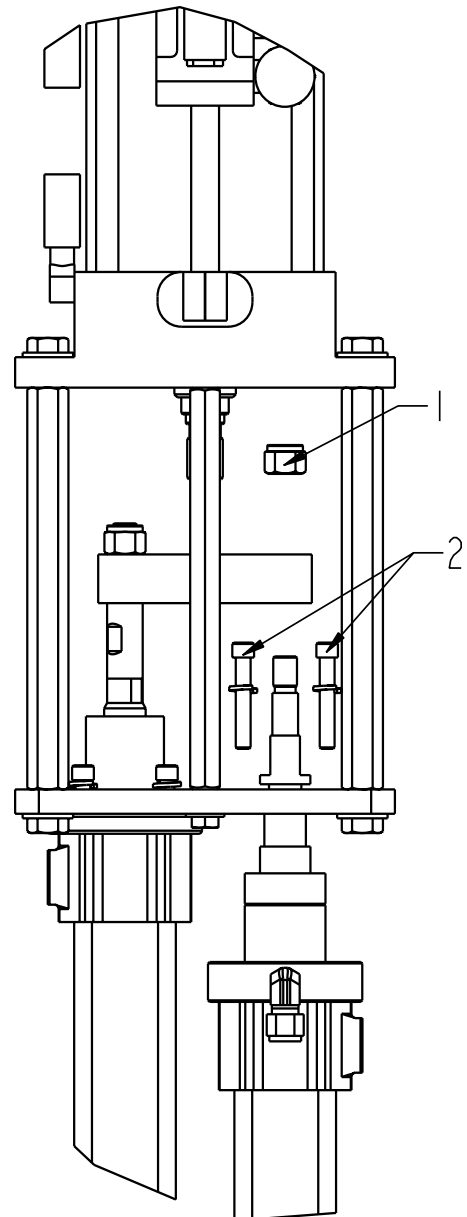
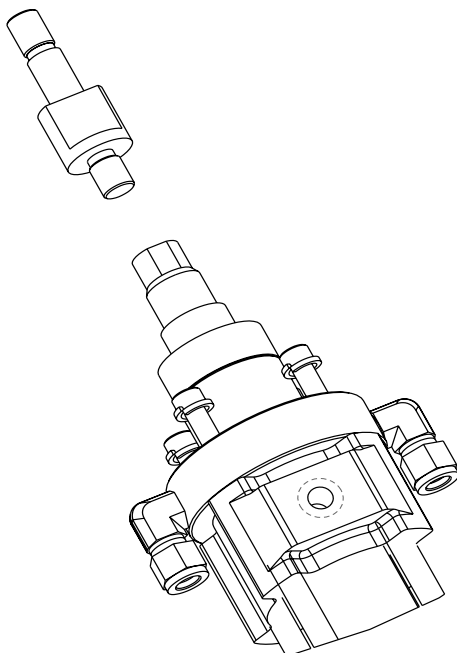

## Section 1 - Installation

Sec. 1:3

14. Reinstall the safety guards.

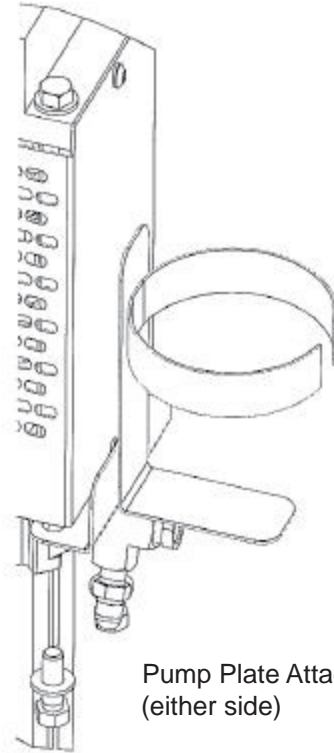
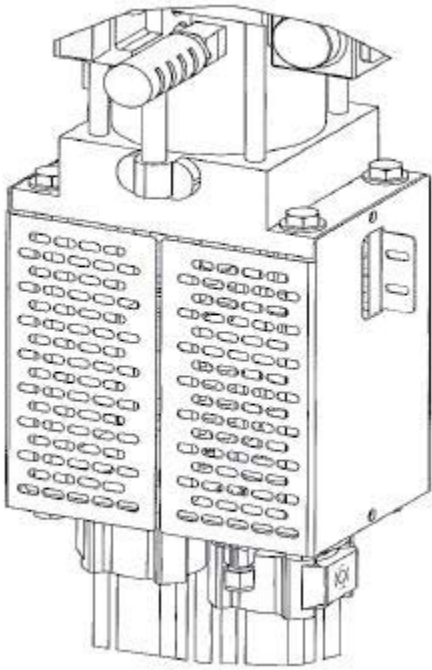

Pump Plate Attachment  
(either side)

15. Assemble the bottle bracket GC1840 (included with kit) to the fluid section. The bottle bracket can be attached to either side of the air motor or either side of the pump plate as shown.

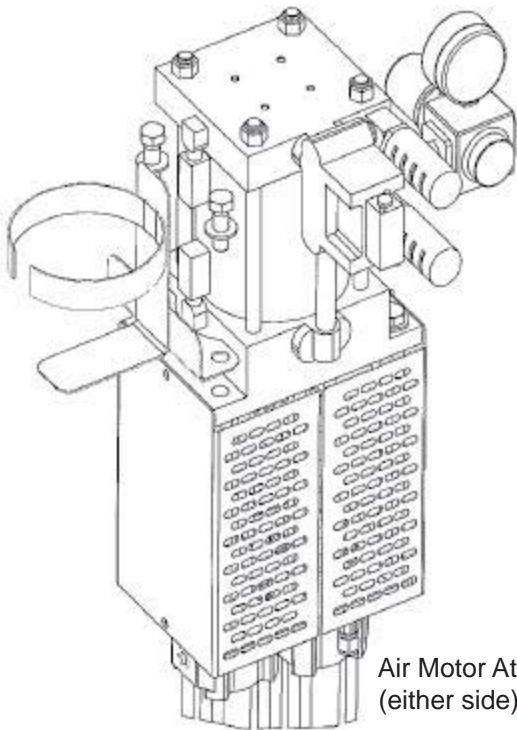

Air Motor Attachment  
(either side)

16. a. Install the plastic bottle GC1831 (included with kit) to the bottle bracket.

b. Assemble the tubing (included with kit) from the plastic bottle to the fittings on the ISO pump.

 Mount the bottle bracket to the top for hydraulic units.



## Section 2 - General Information: Assembly Drawing

<b>GC1845</b>			
<b>Fluid Section Recirculation kit</b>			
Ref.	Part	Description	Qty.
1	GC0430	ELBOW FITTING	2
2 ❖	GC1831	PLASTIC BOTTLE	1
3	GC1834	SPRING	2
4	GC1836	SOLVENT CUP ADAPTER	1
5	GC1837	SOLVENT CUP INSERT	1
6	GC1838	PISTON	1
7	GC1839	SHAFT EXTENSION	1
8 ❖	GC1840	BOTTLE BRACKET	1
9	GC1841	SPRING	1
10	GC1928	O-RING	2
11	GC1929	O-RING	1
12	GC1930	O-RING	1
13	GC1934	O-RING	1
14	GC1843	STEEL BALL	2
15 ☆❖		TUBING; 6 FT.	
16	GC2256	SCREW	4
17	GC2110	SPRING WASHER	4

☆ Purchase locally.

❖ Not shown.

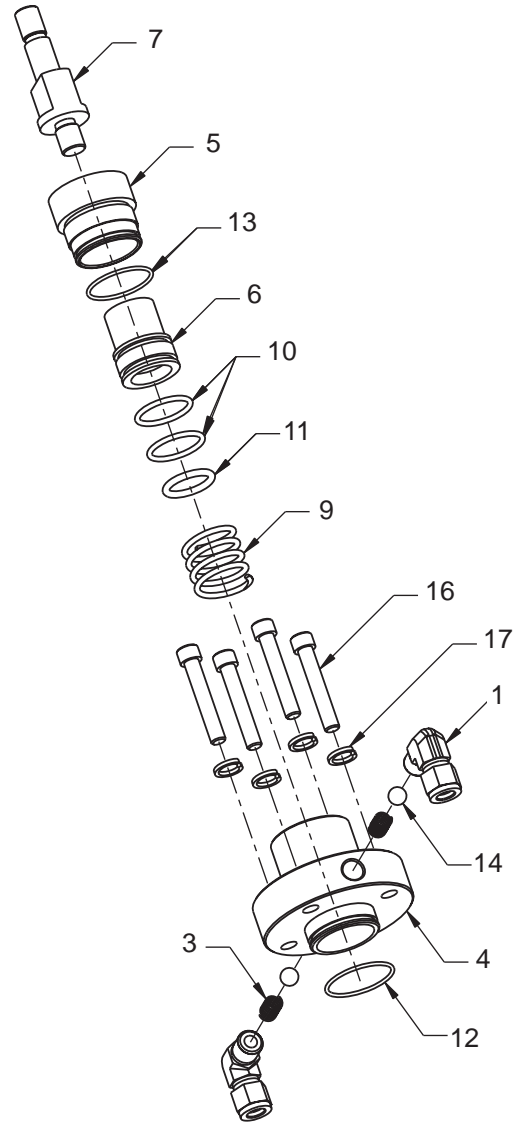

Sec. 2:1



Flush material that is used **MUST** be compatible with the following products:

- EPR
- Polyethylene UHMW

- It **MUST** also be compatible with out volitant reaction to the material system used.  
Consult the material manufacture before use.

- GlasCraft Suggestions:
- Light weight non-detergent oil
- Dynasolve dynaflush



## Section 3 - Warranty and Reference Information: Limited Warranty Policy

### Graco Standard Warranty

Graco warrants all equipment referenced in this document which is manufactured by Graco and bearing its name to be free from defects in material and workmanship on the date of sale to the original purchaser for use. With the exception of any special, extended, or limited warranty published by Graco, Graco will, for a period of twelve months from the date of sale, repair or replace any part of the equipment determined by Graco to be defective. This warranty applies only when the equipment is installed, operated and maintained in accordance with Graco's written recommendations.

This warranty does not cover, and Graco shall not be liable for general wear and tear, or any malfunction, damage or wear caused by faulty installation, misapplication, abrasion, corrosion, inadequate or improper maintenance, negligence, accident, tampering, or substitution of non-Graco component parts. Nor shall Graco be liable for malfunction, damage or wear caused by the incompatibility of Graco equipment with structures, accessories, equipment or materials not supplied by Graco, or the improper design, manufacture, installation, operation or maintenance of structures, accessories, equipment or materials not supplied by Graco.

This warranty is conditioned upon the prepaid return of the equipment claimed to be defective to an authorized Graco distributor for verification of the claimed defect. If the claimed defect is verified, Graco will repair or replace free of charge any defective parts. The equipment will be returned to the original purchaser transportation prepaid. If inspection of the equipment does not disclose any defect in material or workmanship, repairs will be made at a reasonable charge, which charges may include the costs of parts, labor, and transportation.

**THIS WARRANTY IS EXCLUSIVE, AND IS IN LIEU OF ANY OTHER WARRANTIES, EXPRESS OR IMPLIED, INCLUDING BUT NOT LIMITED TO WARRANTY OF MERCHANTABILITY OR WARRANTY OF FITNESS FOR A PARTICULAR PURPOSE.**

Graco's sole obligation and buyer's sole remedy for any breach of warranty shall be as set forth above. The buyer agrees that no other remedy (including, but not limited to, incidental or consequential damages for lost profits, lost sales, injury to person or property, or any other incidental or consequential loss) shall be available. Any action for breach of warranty must be brought within two (2) years of the date of sale.

**GRACO MAKES NO WARRANTY, AND DISCLAIMS ALL IMPLIED WARRANTIES OF MERCHANTABILITY AND FITNESS FOR A PARTICULAR PURPOSE, IN CONNECTION WITH ACCESSORIES, EQUIPMENT, MATERIALS OR COMPONENTS SOLD BUT NOT MANUFACTURED BY GRACO.** These items sold, but not manufactured by Graco (such as electric motors, switches, hose, etc.), are subject to the warranty, if any, of their manufacturer. Graco will provide purchaser with reasonable assistance in making any claim for breach of these warranties.

In no event will Graco be liable for indirect, incidental, special or consequential damages resulting from Graco supplying equipment hereunder, or the furnishing, performance, or use of any products or other goods sold hereto, whether due to a breach of contract, breach of warranty, the negligence of Graco, or otherwise.

#### FOR GRACO CANADA CUSTOMERS

The Parties acknowledge that they have required that the present document, as well as all documents, notices and legal proceedings entered into, given or instituted pursuant hereto or relating directly or indirectly hereto, be drawn up in English. Les parties reconnaissent avoir convenu que la rédaction du présente document sera en Anglais, ainsi que tous documents, avis et procédures judiciaires exécutés, donnés ou intentés, à la suite de ou en rapport, directement ou indirectement, avec les procédures concernées.

### Graco Information

TO PLACE AN ORDER, contact your Graco distributor or call to identify the nearest distributor.  
Phone: 612-623-6921 or Toll Free: 1-800-328-0211 Fax: 612-378-3505

PARA EFETUAR ENCOMENDAS OU PARA ASSISTÊNCIA TÉCNICA, contate o seu distribuidor da Graco.  
POUR PLACER UNE COMMANDE OU DEMANDER DU SERVICE, contactez votre distributeur Graco.  
PARA REMITIR UN PEDIDO O SOLICITAR SERVICIO, póngase en contacto con el distribuidor de Graco.

## Section 3 - Warranty and Reference Information: Technical Assistance

### ***Thank You for selecting GlasCraft spray equipment***

*Should you have any questions or need technical assistance, contact your factory authorized GlasCraft distributor.*

Distributor: \_\_\_\_\_

Phone: \_\_\_\_\_

Contact: \_\_\_\_\_



For any issues your distributor cannot address, the GlasCraft technical service department is always available to assist you with the operation of your spray equipment. To help our technical representatives expedite your call and better address your questions, please have the following information ready and available when you phone GlasCraft.

**\* If your questions are not urgent, please call 1-800-328-0211.**

Model: \_\_\_\_\_

Serial number: \_\_\_\_\_

Type of spray gun: \_\_\_\_\_

Serial number: \_\_\_\_\_

Is your equipment:

Single phase: \_\_\_\_\_ Three phase \_\_\_\_\_

What is the inbound voltage  
to your equipment: \_\_\_\_\_

Temperature setting ISO: \_\_\_\_\_

Temperature setting POLY: \_\_\_\_\_

Temperature setting HOSE: \_\_\_\_\_

### **For Air Powered Systems:**

Air compressor size: \_\_\_\_\_

CFM generated: \_\_\_\_\_

Pressure at the system:

Hydraulic \_\_\_\_\_ Pneumatic \_\_\_\_\_

Dynamic fluid pressure:

ISO \_\_\_\_\_ POLY \_\_\_\_\_

Spray gun chamber size: \_\_\_\_\_

Material being sprayed: \_\_\_\_\_

Viscosity: ISO \_\_\_\_\_ POLY \_\_\_\_\_

Approximate material temperature: \_\_\_\_\_

For Your Reference



**Date Purchased** \_\_\_\_\_  
**Distributor** \_\_\_\_\_  
\_\_\_\_\_  
**Contact** \_\_\_\_\_  
**Phone** \_\_\_\_\_  
**E-mail** \_\_\_\_\_

GlasCraft manufactures a complete line of polyurethane foam and polyurea coating spray systems. If your application is in-plant or a field contractor - GlasCraft has a system package to meet your requirements.

***GUARDIAN - AIR POWERED / A5 & A6 SERIES EQUIPMENT***

- . 6000 OR 12000 WATTS OF HEAT
- . 1600, 2200, OR 3000 PRESSURE SET-UPS AVAILABLE

***MH, MH II, & MH III HYDRAULIC POWERED SYSTEMS***

- . UP TO 45 LBS / MINUTE OUTPUT
- . EXCELLENT PERFORMANCE AND RELIABILITY

***GUARDIAN MMH - MOBILE MODULAR HYDRAULIC SYSTEMS***

- . SPECIFICALLY DESIGNED FOR ANY TYPE OF SPRAY RIG
- . GIVE COMPLETE UTILIZATION OF FLOOR SPACE IN MOBILE RIG

***PROBLER P2 SPRAY GUN***

- . IMPINGEMENT MIX / AIR PURGE
- . OPTIONAL NOZZLE FOR SPRAYING STUD WALLS, POURING & STREAM JET

For more information concerning any of these GlasCraft products,  
contact your local authorized GlasCraft distributor or visit [www.glascraft.com](http://www.glascraft.com)

Quality and Performance...

GENUINE GLASCRAFT

**Glas**.....**Craft**

DISPENSING EXCELLENCE



[www.glascraft.com](http://www.glascraft.com)

313285A

GRACO INC.  
P.O. BOX 1441  
MINNEAPOLIS, MN 55440-1441

Phone	612-623-6921
Toll Free	1-800-328-0211
Fax	612-378-3505