

Cleanout Tool Kit

Probler P2 Plural Component, Impingement Mix Air
Purge Spray Gun

407052C

EN



Important Safety Instructions

Read all warnings and instructions in the
Probler P2 Spray Gun manual.

NOTE: Do not drill into metal during cleanout operation.

Use N Methyl Pyrrolidone (NMP), Dynasolve CU-6, Dzolv, or
equivalent to soften cured material.

NOTICE

These solvents are not recommended for flushing.

Kit 24R737

See illustration on page 2.

Ref.	Port Description	Diameter in. (mm)	Cleanout Drill Part No.
A1	Exhaust Port	0.104 (2.6)	127060
A2		5/16 (7.9)	127055
B1	Exhaust Port	0.104 (2.6)	127060
B2		5/16 (7.9)	127055
C	Cross Ports	1/8 (3.1)	119641
D1	Supply Lines	1/8 (3.1)	119641
D2		5/32 (3.9)	296185
E1	Spool Bore	17/64 (6.7)	296306
E2		13/32 (10.3)	127056
F1	Air Inlet Port	7/16 (11.1)	127057
F2		5/16 (7.9)	127055
F3		1/4 (6.4)	127058
G	Grease Port	13/64 (5.2)	127059
H	Bore	5/16 (7.9)	127055

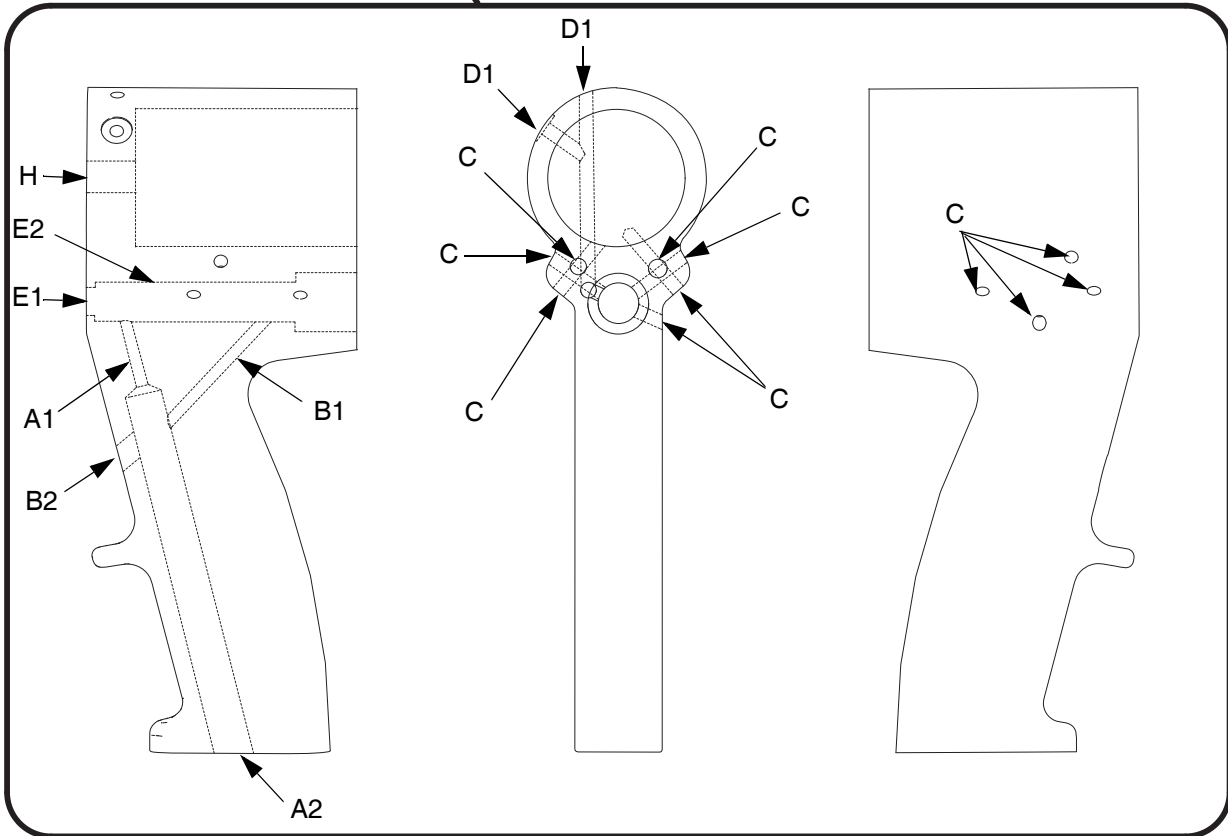
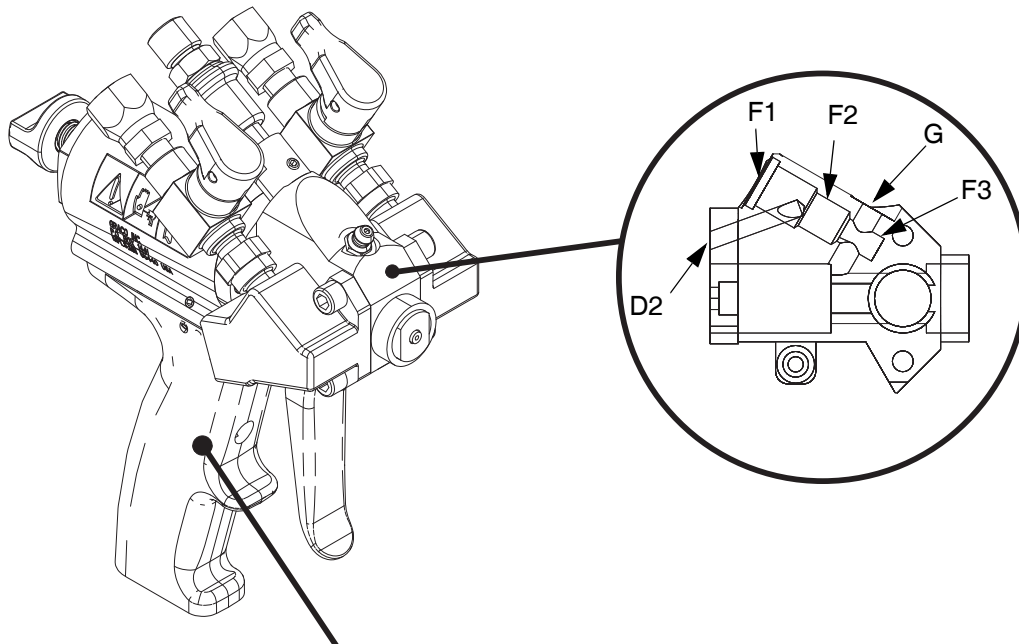

ti20706a

GRACO INC. AND SUBSIDIARIES • P.O. BOX 1441 • MINNEAPOLIS MN 55440-1441 • USA
Copyright 2013, Graco Inc. All Graco manufacturing locations are registered to ISO 9001.

407052, Revision C, November 2018